

APPLICATION:
 JOB NAME:
 QUANTITY: ITEM NO.

PRODUCT NAME:
 PRE-RINSE, SWIVEL STYLE,
 DECK MOUNT
 SPECIAL CONFIGURATION
 CHECK BASE MODEL AND OPTIONS
 MODEL:
 2311 ULTRA SPRAY VALVE NO WALL BRACKET
 2311-WB ULTRA SPRAY VALVE W/ WALL BRACKET

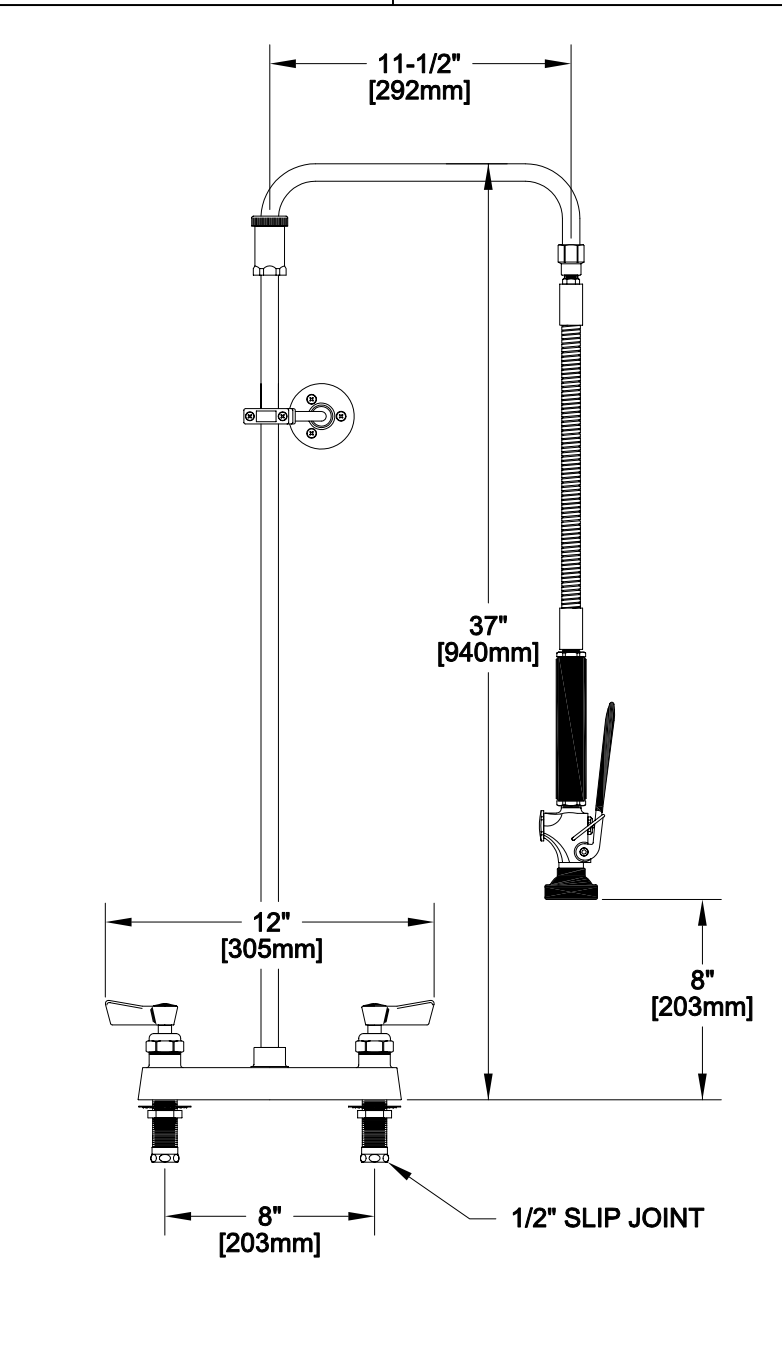

OPTIONS OR MODIFICATIONS:
 SUPPLY LINES (24" OR 36") CIRCLE LENGTH
 ADD-ON FAUCET (6", 8", 10", 12", 14", 16") CIRCLE
 IN-LINE DUAL CHECK VALVE
 PIPE HOOK
 BRUSH
 HANDLES (CROSS OR WRIST) CIRCLE STYLE
 VANDAL RESISTANT KIT
 OTHER _____

FEATURES
 CONTROL VALVE
 * 8" DECK MOUNT
 * INTERNAL SPRING LOADED CHECK VALVES
 * HOT SIDE STEM - RIGHT HAND
 * COLD SIDE STEM - LEFT HAND
 * SWIVELLING SEAT DISKS
 * STAINLESS STEEL SEATS
 * STAINLESS STEEL SEAT SCREWS
 * STAINLESS STEEL HANDLE SCREWS

HOSE
 * 15-1/2" LENGTH
 * STAINLESS STEEL END FITTINGS
 * STAINLESS STEEL EXTERNAL JACKET
 * 3-PLY FIBER REINFORCED INTERNAL RUBBER HOSE

ULTRA SPRAY VALVE
 * LOWEST ENERGY USER - 1.15 GPM @ 60 PSI
 * CLEANS FASTER - TEST PROVEN
 * ENGINEERED TO LAST - NO 'O' RINGS TO LEAK
 * INTERCHANGEABLE - FITS ALL BRANDS

SYSTEM LIMITS
 * TEMP: 40°F MIN. TO 140°F MAX.
 * PRESSURE: 200 PSI MAX. STATIC

SHIPPING WEIGHT
 * 12.0 LBS

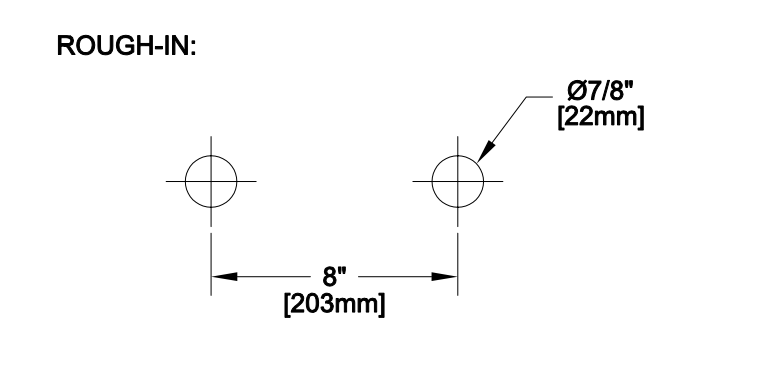

FISHER
 FISHER MANUFACTURING COMPANY
 TOLL FREE: 800-421-6162 - FAX: 800-832-8238
 information@fisher-mfg.com - www.fisher-mfg.com